

Installation and Operating Instructions for Electric heater-circulator unit EPR

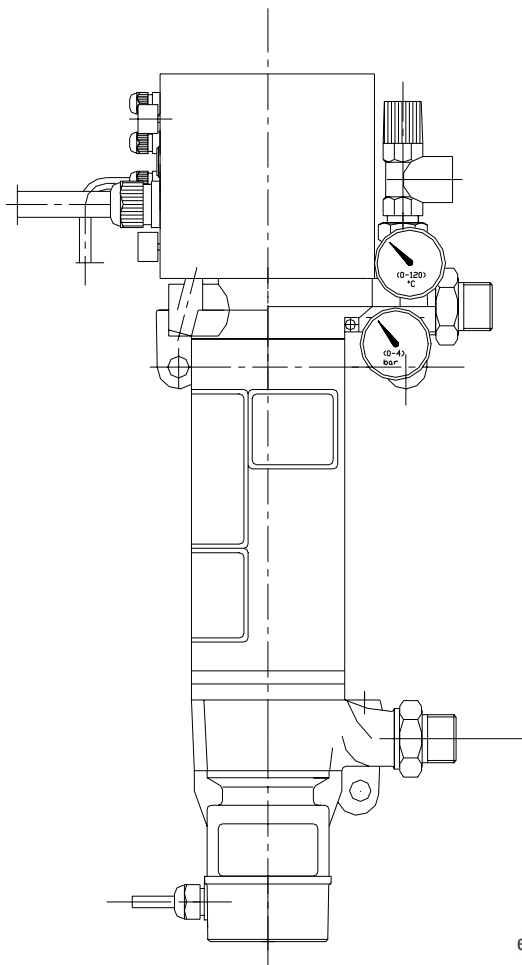

LAING

einfach · gut · aus prinzip

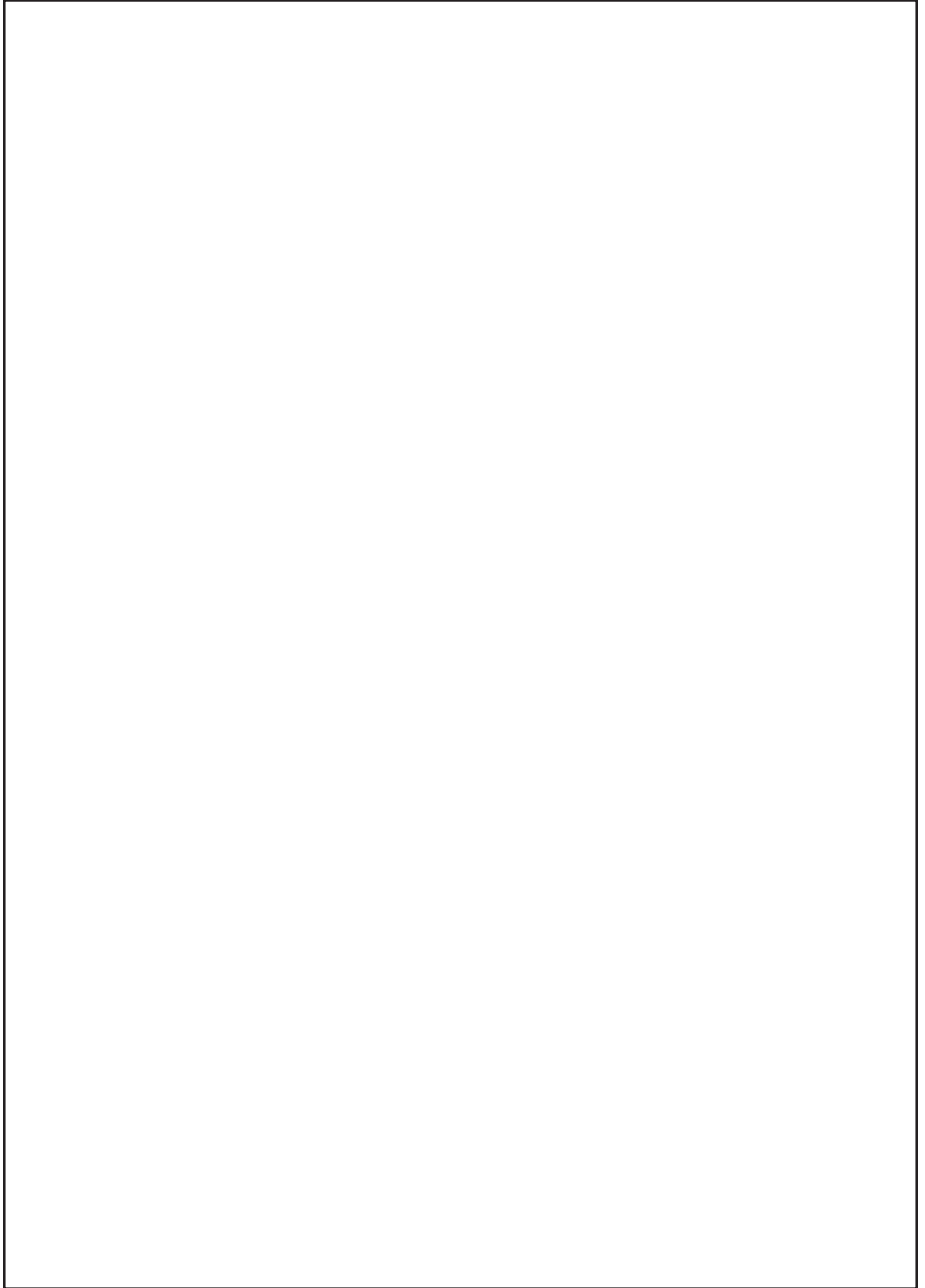

- A Terminal strip for Mains connection
- E Ground terminal
- F Fuse for pump
- H Main switch
- I Jumper wires for remote control input and pump module input
- J Jumper 1 to 8
- K Constant temperature control
- L LEDs
- M Mounting screws for printed circuit board (behind terminal bracket)
- N Cable entry for Mains connection
- R Cable entry for control and circulator
- S Safety temperature limiter
- U Fuse for control
- V Terminals
- Z Reset knob for safety temperature limiter

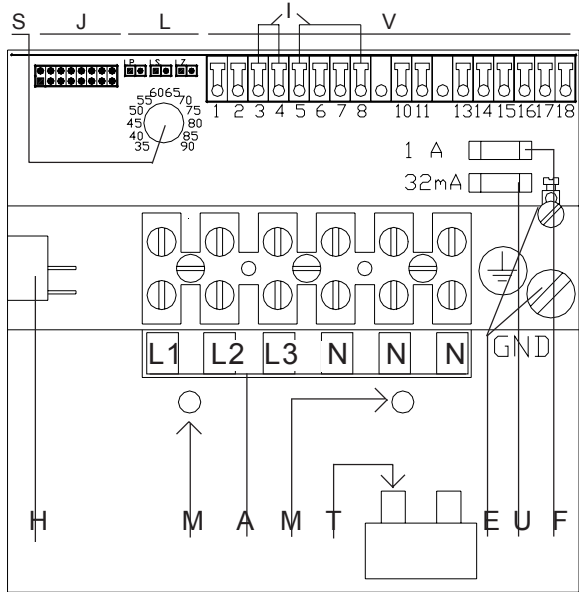

Jumperposition

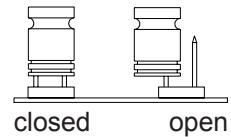

Terminal usage

- 1,2 Remote control for heating elements 2 and 3
- 3,4 Input from pump module
- 5,6 Remote control input
- 7,8 Remote control input
- 10,11 Potential free output for remote trouble indicator
- 13,14 Power supply for daughter board EPRBW
- 15,16 Power supply for circulator
- 17,18 used only for FP 5000 ER models

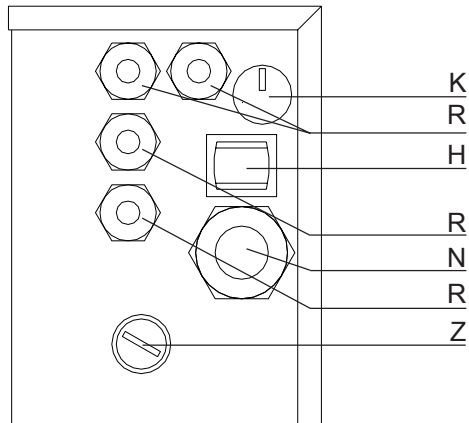

See next to last page for jumper positions and error indicators.

Contents

Applications	5
Design of the EPR model	5
Technical Data	6
Dimensional Drawing	7
Performance Curve	7
Models Available	8
Mounting	9
Connection to the feed and return line	9
Electrical Connection	10
Power Supply	10
400V N3 Electrical Diagram	10
230V N1 Electrical Diagram	11
230V N3 Electrical Diagram	11
The integrated control	12
Schematics of the integrated control	12
Design of the Main Printed Circuit Board	13
Main switch	14
Fuses	14
Constant temperature control	14
Overheating Protection	14
Program selection for the switching sequence of the heating elements	15
Pump shut-off	17
Deactivating heating elements	17
Remote control of the second and third heating element	17
Control input	18
Room temperature guided control	18
Outside temperature guided control	20
Safety temperature limiter	20
Electronic means to prevent dry running	21
Circulator operation control	21
Malfunction detector	22
Attachment of the sensor for the remote control	23
Indirect domestic hot water heating with the Electric heater-circulator EPR	24
Hydraulic connection of the EPR for domestic hot water heating	25
Electrical connection of the EPR for domestic hot water heating	26
Control method 1	26
Control method 2	27
Operation of heating elements with a load shedding device	28
Filling of the system	30
Pressure and leak tests	30
Starting operation	30
Replacement of the circulation pump	31
Replacement of the safety temperature limiter STBR	31
Replacement of the main circuit board EPRH	32
Important Notices	32
Important Notice: How to avoid overheating	32
Important Notice: In the event of safety temperature limiter failure	33
Important Notice: For proper connection to a floor heating system	33
Factory settings	33

Applications

Electric heater circulator units Model EPR can be applied in all cases where electric heating has to be installed in a small space to heat an apartment or a single or multiple family house.

This applies to direct electrical heating as well as for electrical heating with a heat storage.

A further application exists in connection with room additions where the electric heating can supplement the existing hydronic heating.

The Electric heater-circulator is also very well suited to heat domestic hot water. The application for heating of domestic hot water is described in "Indirect domestic hot water heating - Application".

Design of the EPR model

The Electric heater circulator model EPR consists of a circulator pump, an electric heater with three heating elements and an electronic microprocessor control.

The spherical motor circulator operates almost noiselessly and stays quiet over its lifetime.

The arrangement of the pump below the heating elements guarantees good heat conductivity from the heating elements since the swirl created by the impeller extends over the length of the heating elements. This avoids overheating of the heating element surfaces.

The water for the heating loop is drawn in by the circulator, conveyed along the heating elements and discharged through the discharge port at the upper part of the housing. The inlet has an additional 3/8" port, to which an expansion tank can be connected. An automatic air vent and a pressure relief valve communicate with the outlet port.

Mounting eyelets are included in the castings of the unit.

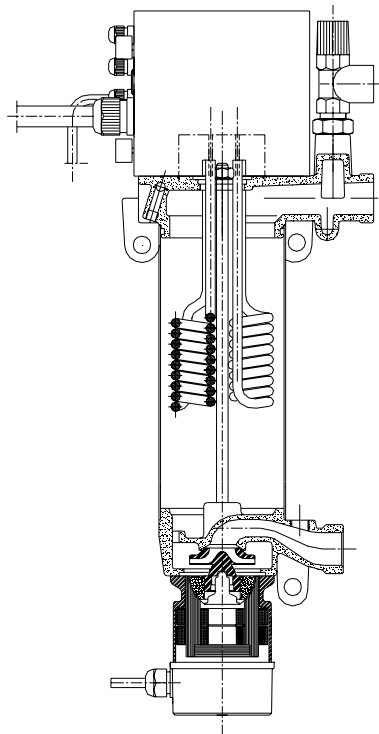

The Electric heater circulator units EPR 6 to EPR 15 differ only in the performance of the electrical heating elements and the distance between the ports. EPR 6 has a heating performance of 6000 W, EPR 9 has 9000 W, EPR 12 has 12000 W and EPR 15 has 15000W.

The control unit, which controls a variety of control and safety functions, is arranged on top of the Electric heater circulator.

Technical Data

Model	EPR 6	EPR 9	EPR 12	EPR 15
Pmax.			6 bar	
Tmax.			90°C	
Connection on water side			Union 1" male	
Weight	9.9 kg	10.2 kg	10.8 kg	11.1 kg
Pump				
Max. Head			32 kPa	
Max. Flow			3.4 m ³ /h	
Motor				
Design			Shaftless spherical motor	
Watts Input			99 W	
Motor performance			35W	
Volts AC			230 V	
Amperes			0.43 A	
Electric Heater				
Electrical performance	6 kW	9 kW	12 kW	15 kW
Number of heating elements	3	3	3	3
Heat capacity per element	2 kW	3 kW	4 kW	5 kW
Voltage	400 V, 3P	400 V, 3P	400 V, 3P	400 V, 3P
Amperes	8.7 A	13.0 A	17.4 A	21.6 A
Connection	Y	Y	Y	Y
Safety Temperature Limiter				
Maximum temperature			95°C+/- 5 K	

Dimension Drawing

Dimension in mm

Model	A	B
EPR 6	300	601
EPR 9	300	601
EPR 12	365	666
EPR 15	365	666

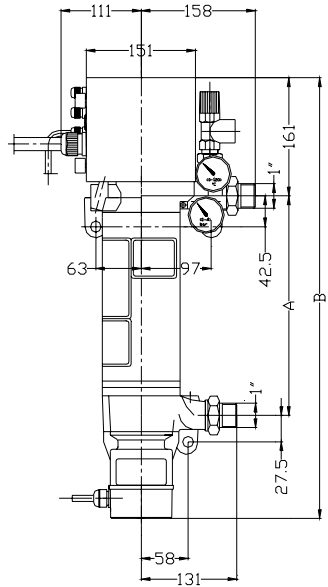

Performance

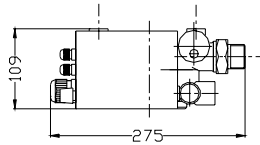
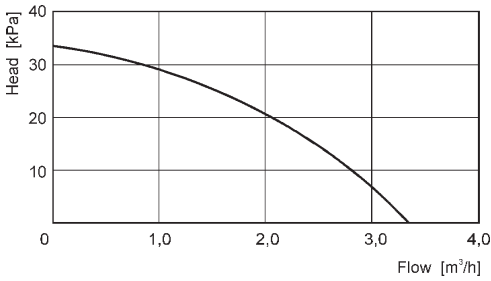

Models Available

Electric heater circulator unit

The Electric heater circulator units are available in four heat outputs

Model	heat capacity	Item No.
EPR 6	3 x 2 kW	40 00 300
EPR 9	3 x 3 kW	40 00 330
EPR 12	3 x 4 kW	40 00 360
EPR 15	3 x 5 kW	40 00 390

Central Station

The Central Station model EPRZ contains the Electric heater circulator unit, a corrosion resistant 6 liter expansion tank, a safety fittings and shut-off ball valves.

Model	heat capacity	Item No.
EPR 6 Z	3 x 2 kW	51 00 300
EPR 9 Z	3 x 3 kW	51 00 330
EPR 12 Z	3 x 4 kW	51 00 360
EPR 15 Z	3 x 5 kW	51 00 390

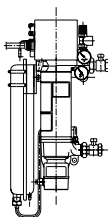

Controls

Controls for heating systems in connection with LAING Electric heater circulator units

Model	Item No.
Constant temperature control integrated in the EPR control	
Room temperature guided control	
RT	55 00 050
Room temperature guided control with timer	
RTU	55 00 404
Outside temperature guided control	
AR 1000d	55 00 150

Compact units with Electric heater circulator unit

Compact units are provided with an Electric heater circulators unit, a pressurized expansion tank, safety valves, manifolds including control valves¹⁾, adjustable flow meters and a check valve. The units are completely assembled, leakage tested and installed in a galvanized steel cabinet or on mounting brackets.

Model	Item No.
EPR 6 SD ²⁾	53 00 000 ³⁾
EPR 9 SD ²⁾	53 00 050 ³⁾
EPR 12 SD ²⁾	53 00 100 ³⁾
EPR 15 SD ²⁾	53 00 150 ³⁾
(in cabinet)	
EPR 6 XD ²⁾	53 00 500 ³⁾
EPR 9 XD ²⁾	53 00 550 ³⁾
EPR 12 XD ²⁾	53 00 600 ³⁾
EPR 15 XD ²⁾	53 00 650 ³⁾

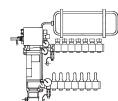
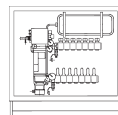

(on mounting brackets)

- 1) with order indicate size of compression fitting
- 2) add the number of heating loops to the Model number
- 3) add the number of loops to the Item number.

Example:

A compact unit with Electric heater circulator unit EPR 9000 in a galvanized steel cabinet with 11 heating loops has the Item number 53 00 061 and the Model number EPR 9000 SD 11.

Accessories, parts, spare parts

Model	Item No.
Safety temperature limiter	
STBR	55 00 921
Main printed circuit board	
EPRH	55 00 927
Printed circuit board for indirect domestic hot water heating	
EPRBW	55 00 929

Mounting

For safety reasons, the Electric heater circulator must be mounted on a fireproof base. In addition, the unit must be installed with the circulator motor pointing downwards!

The unit must be attached to a flat wall with the help of the mounting eyelets arranged at the top of the unit and at the pump housing. To avoid noise transfer to the wall, both sides of the mounting eyelets have to be covered with rubber insulators. The rubber insulators are supplied with the Electric heater circulator unit and have to be mounted in such a way that no metal contact exists between the castings and the fastening screw. In addition, no part of the Electric heater circulator unit - for example the outer shell or the pump - should be in contact with the wall.

The Electric heater circulator should be mounted at least 60 mm above the floor to allow replacement of the circulator motor if necessary.

Connection to the feed and return line

The unit is connected to the heating loop by 1" male threaded fittings. The feed line is at the top of the unit, the return line at the bottom. The expansion tank should be connected to the 3/8" port next to the return line. If the expansion tank cannot be connected there, it should be connected somewhere else in the return line, but not in the feed line. There are two 1/2" ports at the top of the unit. The automatic air vent for the heating circuit is connected to the 1/2" port closest to the wall, the pressure relief valve to the port in front.

When the Electric heater circulator unit is used solely for floor heating, the chapter "Important Notice: Proper connection to a floor heating system" has to be observed.

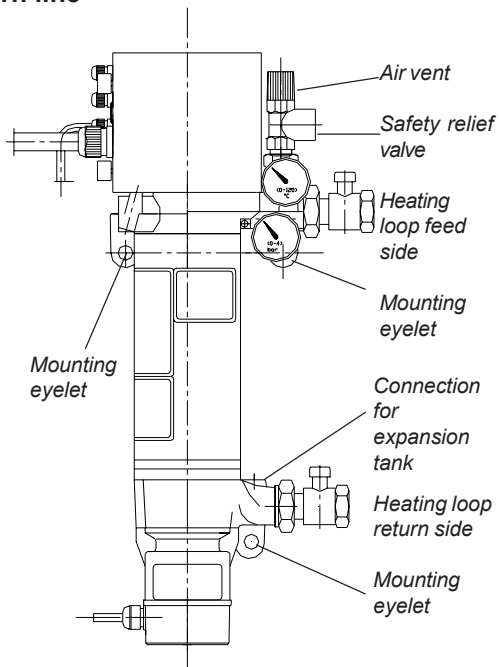

Connection EPR series

Electrical Connection

Notice: The electrical connection has to be performed by a licensed electrician!

The pump must not be operated without water.

To make the electrical connections, the control box at the top of the heater has to be opened by removing the 4 screws. A cable with a sufficient cross section for the performance of the Electric heater circulator unit has to be inserted through the strain relief and connected to the input terminal (see Electrical Diagram below)

The circulator is already wired to the control box.

Power Supply

The Electric heater-circulator is designed for three different kinds of power supply. In all cases the following information has to be taken into account:

The electronic switches integrated into the Electric heater circulator unit do not separate the heating elements from the power supply. Therefore, a master switch that interrupts all phases has to be installed in an accessible place, taking into account all applicable safety codes.

As a protection for the semiconductor relays each phase has to have a fast acting fuse.

400V N3 Electrical Diagram

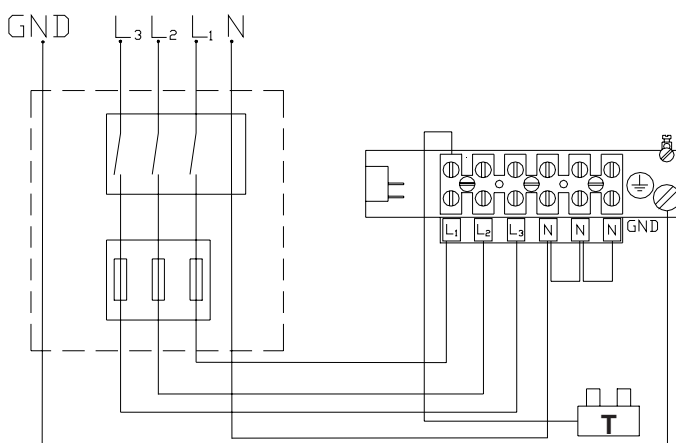

230V N1 Electrical Diagram

In this case, the Electric heater circulator unit has to be connected with 7 leads to protect each of the semiconductor relays separately. After this has been done, the leads are combined into one phase.

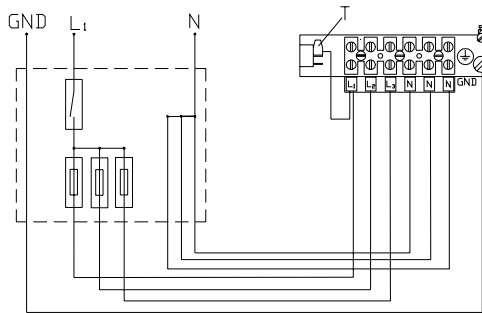

T

230V N3 Electrical Diagram

In this case, it is important to ensure the proper phase sequence of the connectors 1 to 3 and 4 to 6.

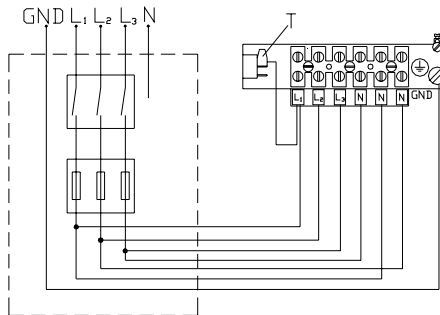

T

The integrated control

The integrated microprocessor control in the housing on top of the Electric heater circulator unit performs a variety of control functions for a large number of applications.

The heating elements are noiselessly switched by electronic relays.

Schematics of the integrated control

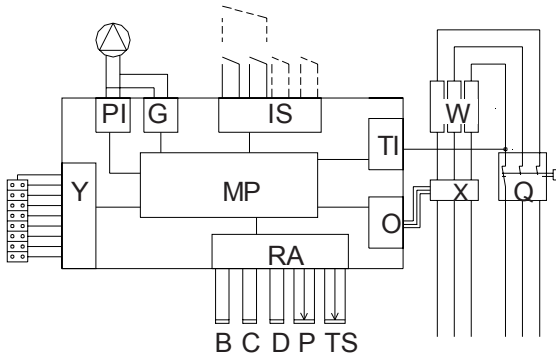

The block diagram shows the control in schematic presentation

- B Temperature sensor for feed temperature
- C Temperature sensor for the safety temperature limiter
- D Temperature sensor for the semiconductor relays
- G Pump operation control logic
- IS Input for external control and remote control
- MP Microprocessor
- O Control for the semiconductor relays
- P Potentiometer for constant temperature setting
- PI Pump performance control
- Q Safety temperature limiter
- RA Analog inputs for temperature sensors and temperature pre-selection
- T Potentiometer for safety temperature setting
- TI Safety temperature limiter control logic
- W Heating elements
- X Semiconductor relays
- Y Jumper settings for operation mode

Temperature sensor B monitors the temperature of the feed line water and passes the information on to the microprocessor. The microprocessor then activates the solid state relays which in turn activate the heating elements according to the jumper selected program. An independent sensor C also monitors the temperature of the feed line water and switches the pump off when the temperature exceeds a pre-set temperature.

A further sensor D monitors the temperature of the solid state relays and turns off the heating elements in case of overheating.

A special control logic verifies the rotation of the circulator and prevents the heating elements from being turned on if the circulator is not running. The safety temperature limiter turns the heating elements off permanently - independent of the electronic control - when the temperature exceeds 90°C.

Design of the Main Printed Circuit Board

(See also page 2)

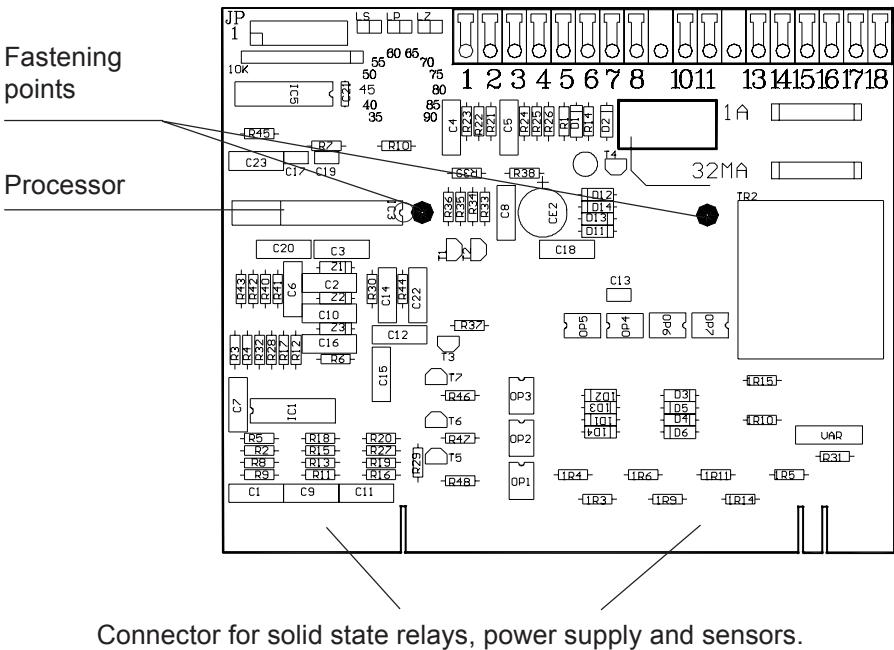

Functions

Main switch

The Electric heater circulator unit contains a main switch H which powers the electronic control and thereby also controls on – off operation of the heating elements. The main switch does not separate the unit from the main power supply. This separation must be provided on site, taking in consideration all applicable safety codes.

Fuses

To protect the electronic components, the control contains two fuses. The 35mA fuse protects the processor control, the 1A fuse protects the circulator.

Constant temperature control

The constant temperature control function maintains the feed temperature of the Electric heater circulator unit at a pre-set level. This is achieved by measuring the outlet temperature and activating the three heating elements in accordance with the selected program (See “Program selection for the switching sequence of the heating elements”).

The integrated constant temperature function is always activated. Therefore, whenever an external control is used, the constant temperature has to be set at or above the maximum temperature required by the external control.

The constant temperature can be set with the control knob K at the outside of the housing. The range is from 30°C to 85°C.

When the electronic safety temperature limiter function is activated, the selected constant temperature should always be at least 10K lower than the safety temperature. Otherwise, under unfavorable conditions, the safety temperature limiter function could be activated, which would shut down the unit.

Overheating Protection

When the Electric heater circulator unit is used in connection with floor heating it is strongly recommended to activate the integrated overheating protection in order to avoid overheating damages due to failure of the control.

To activate this function, jumper 8 needs to be closed. The safety temperature should be set to the highest permissible temperature for the floor in a range between 35°C and 90°C at the potentiometer S. This temperature must be higher than the maximum temperature reached by the floor heating system under normal conditions!

If activated, the control monitors the feed line temperature with an additional sensor C and switches off the circulator of the Electric heater circulator unit if this temperature exceeds the set temperature. This ensures that - independent of the function of the control – overheating of the floor heating pipes is avoided.

Program selection for the switching sequence of the heating elements

The Electric heater circulator unit has three heating elements, each of which has its own solid state relay. If heat is required, it is normally neither desired nor necessary that all heating elements are switched on simultaneously. While this would load all three phases fully, the activation of all three heating elements could cause overheating at times of off-peak heat demand.

Therefore, several methods can be selected by which the heating elements will not be switched on at the same time, but staged over time. Moving the first jumper between the pins 1 to 4 will perform this task. However, only one of these jumpers should be closed at any time. If by mistake several jumpers have been installed, the red and yellow LEDs start blinking and the unit will not operate.

An overall view of the jumper settings for the switching sequence can be found on the second to last page of this manual.

A The heating elements will always be switched on simultaneously. This kind of function can be used with all temperature control methods. If the utility company does not allow the switching of individual heating elements, this function must be selected. The disadvantage is that all heating elements are activated simultaneously and that all three phases are fully loaded even if the heat requirement is low. If the heat requirement is low, this method can also lead to overtemperature. To select this function, jumper 1 must be closed and jumpers 2, 3 and 4 must be open.

B The heating elements are activated depending on the temperature. This function is only applicable in combination with the integrated constant temperature control and with room temperature guided control which uses the constant temperature function.

This function cannot be used with an outside temperature guided control or another remote control that regulates the feed temperature of the Electric heater circulator unit.

When the feed temperature is 2K below the set temperature of the constant temperature control, the first heating element is switched on. If the temperature drops another 3K, the second heating element is activated.

Another 3K lower, the third heating element is turned on. All heating elements stay on until the set temperature has been reached.

To select this function, the second jumper must be closed and jumpers 1, 3 and 4 must be open.

This control method has been implemented since it is customary in some countries. If permitted, control function D is normally preferable.

- C The heating elements are activated one after another. This control function is applicable to all temperature control applications and should always be used when the feed line temperature is controlled by a remote control, for instance by an outside temperature guided control, or when the utility company does not require that all phases are switched on at the same time. In this case, this method guarantees the highest degree of heating comfort. When the control detects that heat is needed, first one heating element is switched on, after two minutes the second, and after another two minutes the third.

To select this function, jumper 3 must be closed, jumpers 1, 2 and 4 must be open.

- D The heating elements are activated depending on the heat load. This control function is recommended in combination with the integrated constant temperature control, and also with a room temperature guided control, since this also uses the constant temperature function. This function cannot be used in combination with an outside temperature guided control that controls the feed line temperature of the Electric heater circulator unit.

When heat is required, the first heating element is activated. After a stabilizing time of approximately one minute, the control checks whether the temperature is increasing or decreasing. If the temperature is increasing, no further heating elements will be switched on. If the temperature is still decreasing, the second heating element is turned on. After another minute, the temperature change will be checked again, and if necessary, the third heating element will be switched on. All activated heating elements will stay on until the set temperature has been reached. If the actual feed line temperature differs considerably from the set temperature (for instance when the heater is switched on), after approximately one minute all heating elements will be turned on automatically.

To select this function, jumper 4 must be closed and jumpers 1, 2 and 3 must be open.

Pump shut-off

The integrated control is equipped with a pump shut-off option which can be activated by closing jumper 5.

If the pump shut-off function is not activated, the pump operates always when the main switch of the control is switched on. If the pump shut-off switch is activated, the pump only starts when heat is required and runs for about two more minutes after the heating has been turned off, so that all residual heat from the heating elements will have been dissipated.

As a general rule, the pump shut-off option should be activated in heating systems with radiators, while the pump should run continuously in floor heating applications.

This pump shut-off function is independent from the pump switching of the pump shut-off module of a zone control, which prevents the pump from operating when all zone valves are closed. If such a function is desired, a pump shut-off module is required.

Deactivating heating elements

The Electric heater circulator unit contains three heating elements, which can be automatically energized by the control. If not all three heating elements are needed for an application, the second heating element can be deactivated by opening jumper 6 and heating element 3 can be deactivated by opening jumper 7. The deactivated heating elements are no longer activated by the control, unless they are activated by a remote control system.

Remote control of the second and third heating element

This function makes it possible to control the second and third heating elements, which would mean providing one third or two thirds of the heating capacity, via an external contact.

It can be used to avoid a high peak load in the electric supply line. The second and/or the third heating element can, for example, be switched off when the hot water heater is being reheated or when the oven hot plates are simultaneously in use. The same applies when the Electric heater circulator unit is operated in a grid with peak demand usage limitations. In this case, one third or two thirds of the heat capacity can be switched off at peak load times.

It should, however, be taken into account that the heating elements – even when they are switched on via the external contact – are only active when the control signals a heat requirement or when the control, according to the chosen program for the switching sequence, activates this heating element.

In case all heating elements should be switched by a remote control, the control entrance should be used (terminals 5 and 6).

To operate the second heating element by remote control, the heating element has to be deactivated first by opening jumper 6. The same applies to the third heating element. In this case jumper 7 has to be opened. Now a non energized switch can be attached to terminal 1 and 2. Closing this switch will activate the deactivated heating elements.

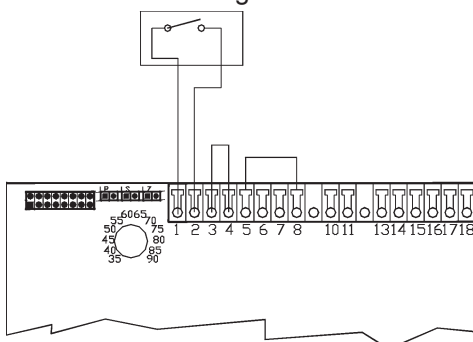

Control input

When the Electric heater circulator unit should be controlled by a remote control unit, this control must be connected to terminals 5 and 8 with a potential free switch. If two remote controls are to operate in series, one can be connected to terminals 5 and 6, the other one to terminals 7 and 8. The terminals 6 and 7 are connected internally. For this function, the bridge between terminals 5 and 8 has to be removed. All active heating elements will be switched on and off by this input in accordance with the selected switching sequence.

The constant temperature control function stays always active. This means that the set constant temperature must be set at or above the maximum temperature called for by the remote control (see also "Outside temperature guided control")

Room temperature guided control

In connection with a room thermostat RT or a room thermostat with timer RTU, it is possible to control the Electric heater circulator unit from one room of the house. In this case, the room thermostat or the thermostat with timer must be connected to the control input of the Electric heater circulator unit. The room thermostat or the thermostat with timer should be located in the main room since it will control the entire heating system.

The thermostat should not be located close to windows, radiators, outside walls or similar distorting influences.

The thermostat should be connected according to the electrical diagram provided with it.

The desired room temperature must be set at the room thermostat. Similarly, the room thermostat with timer should also be properly set. It should be understood that the room thermostat with timer allows only one lower room temperature level, which then will be activated by the timer. There will be no corresponding decrease in the feed line temperature.

Instructions for the operation of the room thermostat with timer should be taken from the manual provided with the unit.

The desired constant temperature for the feed line water, with which the heating system will be heated until the room temperature has been reached, must be set at the setting knob K.

The heating surfaces then will be heated with the preset constant temperature until the preset room temperature has been reached. The heating elements will then be turned off.

It is important that the set constant temperature is always lower than the maximum permissible feed temperature. This is especially important for floor heating applications.

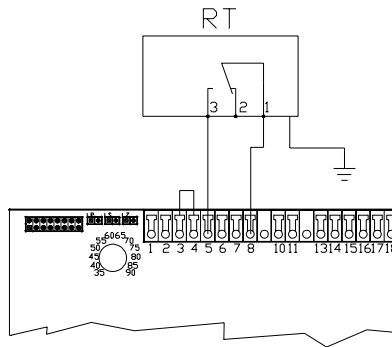

Electrical Diagram RT

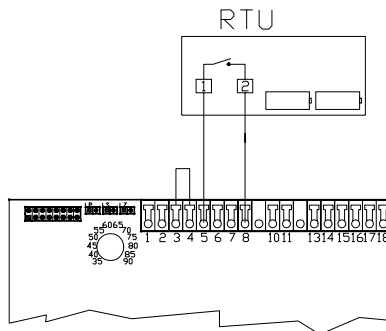

Electrical Diagram RTU

Outside temperature guided control

In connection with the outside temperature guided control AR 1000 d it is possible to control the feed line temperature dependent upon the outside temperature. In this case the switching terminal of the control unit must be connected to the control input of the Electric heater circulator unit and the feed line sensor must be attached to the correct place at the top part of the Electric heater circulator unit. (See also chapter "Installation of the feed line sensor").

The connection should be made according to the electrical diagram provided with the unit. The settings of the outside temperature guided control should be taken from the relevant manual.

The constant temperature control is always active. The constant temperature has to be set at least as high as the highest temperature requested by the outside temperature guided control.

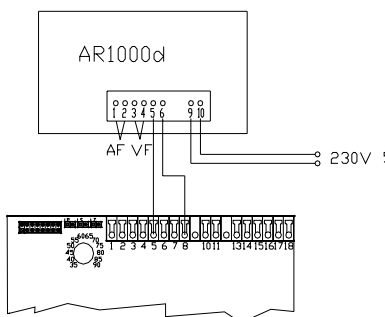

Electrical Diagram AR 1000 d

Safety temperature limiter

In order to protect the Electric heater-circulator from overheating, it is equipped with a safety temperature limiter, which in case of overheating separates one side of the heating element permanently from the grid.

When the safety temperature limiter had been activated, it has to be reset manually by pressing knob Z.

The safety temperature limiter reacts only when there is a malfunction in the system. Therefore, as a first step, the malfunction that caused the activation of the safety temperature limiter has to be corrected.

When the activation of the safety temperature limiter was caused by operating the Electric heater-circulator without water, it is possible that the safety switch could be damaged permanently. In this case it is impossible to reset the safety temperature limiter, it has to be replaced. (See chapter "Replacement of the safety temperature limiter STBR").

Electronic means to prevent dry running

The Electric heater-circulator can only be operated when it is filled with water and the circulator is running.

To protect the heating elements when the Electric heater-circulator is accidentally switched on without being filled with water, or when there is still a lot of air in the system, the control system has electronic dry run protection, which turns the heating elements off and gives a warning via the LED's when the temperature rises too fast.

In this case the red LED lights up, the yellow stays switched off. To reset the system, the unit has to be switched off and then on. If the temperature of the heating elements has fallen below the maximum temperature allowed by the constant temperature control after the unit has been switched off, the heater can be activated again. If the temperature is still too high, the unit has to stay off until the heating elements have cooled down. Of course, the unit has to be filled with water and the air has to be vented. (See chapter "Filling of the system").

The electronic dry run protection safeguards the safety temperature limiter since in a dry run it could be permanent damaged. When the Electric heater-circulator is turned on and off several times after the electronic dry run protection was activated, the safety temperature limiter can nevertheless be damaged. Therefore, after the dry run protection was activated the system first has to be filled with water and the air has to be vented before the unit is switched on again.

Circulator operation control

To avoid the possibility that the heating elements could be switched on while the circulator is not running, the control is equipped with a circulator operation control. This means, that each time before the heating elements are turned on, the control checks whether the rotor of the circulator is rotating. If the rotor is blocked by dirt or if the bearing of the circulator is totally worn, the control recognizes it and the heating elements will not be switched on.

In this case the circulator will be energized for about one minute. The control then tests again whether the rotor is rotating or not. If the rotor still does not rotate, the same procedure is repeated ten times. If the rotor still does not rotate, the control signals malfunction, which is indicated by the blinking of the red LED and shining of the yellow LED.

In this case the circulator has to be removed to find the cause for the malfunction. (See also chapter "Replacement of the circulation pump").

Malfunction detector

The control recognizes the following malfunctions:

(the green LED always shines when the main switch is turned on and there is a connection to the grid; the yellow LED shines when the control requests heat and the heating elements are activated.)

Malfunction	Signal	red LED	yellow LED
Circulator malfunction		blinking	on
Excess temperature cutout		on	on
Safety temperature limiter		blinking	off
Dry run		on	off
Jumper 1 to 4 wrong position		blinking	blinking

The malfunction signal “Jumper 1 to 4 wrong position” means that more than one jumper is closed or all four jumpers are open. Only one of the jumpers 1 to 4 must be closed.

Beside the indication of the malfunction through the LED's on the upper side of the control box, each function effects the closing of a relay which bridges the contacts 10 and 11. This makes it possible to sound an alarm at each malfunction of the Electric heater-circulator, or to activate other heating systems or to inform an overriding control.

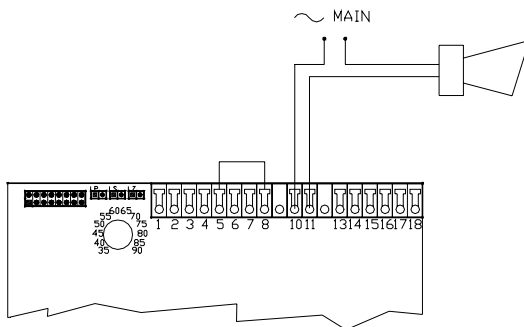

Electrical diagram to address a horn with the alarm output

Attachment of the sensor for the remote control

The sensor for the control of the feed line temperature for an outside temperature guided control can be mounted either on the upper part of the housing that has a hole for a round sensor, or at the feed line of the heating loop, or in the upper part of the tubular shell of the Electric heater-circulator. If the sensor is attached to the feed line or to the manifold, one has to take care that the sensor is in intimate contact with the feed line with the help of heat conducting paste (in no case should the sensor be attached to a plastic part). If the sensor is attached to the manifold of the feed line, the sensor has to be placed before the first loop.

If the sensor is attached to the tubular shell one has to take care that the total surface of the sensor facing the shell is in direct contact and that the sensor is attached to the upper section of the shell!

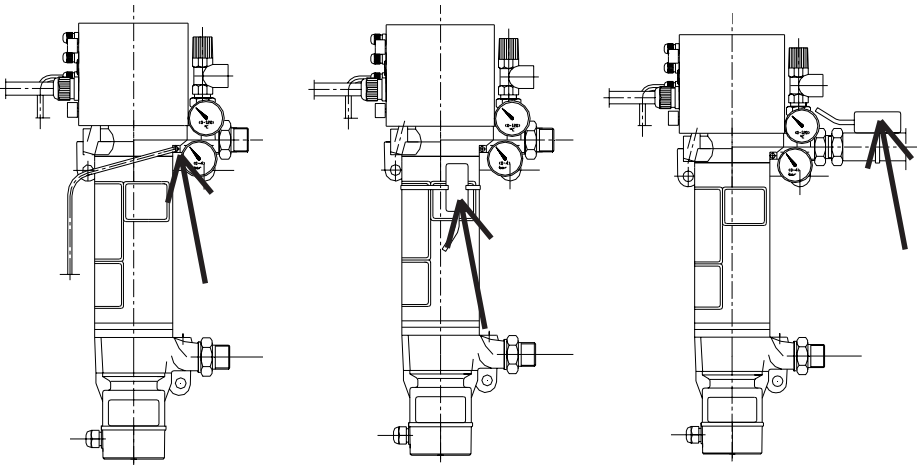

Sensor mounting in the immersion shell:

The sensor will be inserted into the hole at the upper part of the Electric heater-circulator with heat transfer paste.

Sensor mounting at the tubular shell:

The sensor has to be attached as high as possible on the tubular shell. Attention must be paid to insuring good heat transfer contact.

Sensor mounting at the feed pipe:

The sensor has to be attached before the outlet of the first loop and has to have contact to metal.

The sensor for the control can be mounted according to the possibilities shown here.

Indirect domestic hot water heating with the Electric heater-circulator EPR

Indirect domestic hot water heating

During the heating period the heating of the domestic hot water normally is performed by the domestic hot water heater that is essentially a heat exchanger. When hot water is needed, the water from the hydronic heating circuit is conveyed through this heat exchanger by activating the hot water heater priority circuit control. This means that the circulator for the heating circuit is shut off and the charging circulator for the domestic hot water heater is switched on. In addition the temperature of the boiler will be increased to the temperature necessary to heat the domestic hot water.

However, this system can only be operated economically during the heating period. Outside the heating period it is uneconomical to run the boiler just for heating of the domestic hot water. Therefore it is customary, to have an electric heating element beside the heat exchanger within the boiler that heats the domestic hot water outside the heating period.

This method is problematic when the water is extremely corrosive or when the water is hard. It is possible that the heating elements survive only a few month in such a situation.

In these cases it is advantageous to heat the hot water heater outside the heating period also with electricity but indirectly via the Electric heater-circulator EPR that is ideal for this application.

By adding an additional printed circuit the Electric heater-circulator EPR can easily be integrated into existing controls.

Starting operation of the domestic hot water heating and adaptation to seasonal change

To start the Electric heater-circulator the constant temperature has to be set to the desired value, normally about 70°C. The circulator then has to be switched to time delay (close jumper 5) for the switching sequence of the heating elements D, which means, jumper 1,2 and 3 must be open, jumper 4 has to be closed. Now the Electric heater-circulator is ready for operation.

To change to the heating season when the boiler is in operation, the main switch has to be shut off while outside the heating season the main switch has to be turned on. In this latter case the heating of the domestic hot water is performed by the Electric Heater-circulator. Even outside the heating period the boiler control has to stay operational.

Hydraulic connection of the EPR for domestic hot water heating

As can be seen from the following diagrammatic drawings, the Electric heater-circulator will be connected in parallel to the boiler and to the heat exchanger of the hot water heater. To avoid flow through the boiler while heating with the Electric heater-circulator and vice versa, the boiler as well as the Electric heater-circulator is connected via a check valve.

Since the heating system is already equipped with an expansion tank, the Electric heater-circulator does not need a separate expansion tank. The pressure relief valve integrated into the Electric heater-circulator serves as security.

To switch between boiler-heating and electrical heating nothing has to be changed on the hydraulic installation. One has only to take care that instead of the hot water heater circulator the Electric heater-circulator has to be switched on as described in the following chapter.

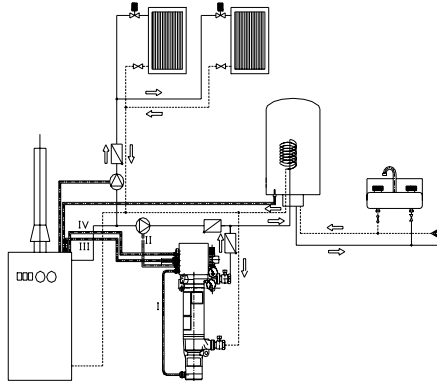

Hydraulic diagram for control process 1

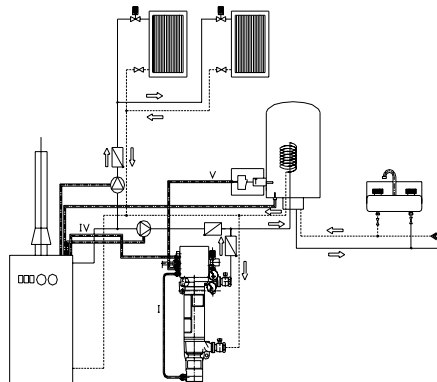

Hydraulic diagram for control process 2

Electrical connection of the EPR for domestic hot water heating

Following two possibilities are described for the connection of the EPR. To guarantee proper operation the exact function of the boiler control has to be known.

During the summer boiler controls with domestic hot water priority circuit control operate by detecting the domestic hot water heater temperature. If the detected temperature falls below the desired temperature there are two versions of operation:

The control starts the burner and the hot water heater feed pump at the same time. If this is the case, it is easily possible to install the Electric heater-circulator EPR as described below under "Control method 1". No additional sensor in the hot water heater is necessary.

The control first turns on the burner and activates the water heater feed pump only when the temperature of the water heater is at least 50°C. Since the burner is switched off during summer time, the control of the domestic hot water heater is only possible with an additional sensor in the hot water heater. In this case one has to follow the diagram described under "Control method 2".

For both control methods the additional printed circuit board Type EPRBW will be needed when the Electric heater-circulator is used to heat the domestic hot water. After removing the cover of the control box this circuit board has to be connected to the terminals 5, 8, 13 and 14 of the main printed circuit board.

Control method 1

The wiring has to be performed according to the wiring diagram shown below, whereby the leads of the hot water heater feed pump loop through the control of the Electric heater-circulator. The lead III of the pump coming from the boiler will be connected to ground and phase at CS1. Lead II leading to the pump will be connected to CS2. In addition a control lead IV will be connected to CS3, which prevents the boiler from turning on as long as the electric heating is activated.

As long as the electric heating is switched off via the main switch the relay on the additional printed circuit board is de-energized and the lead wire for the hot water heater feed pump is properly connected. In addition the control contact of this relay is closed for the burner, so that the boiler now takes care of the heating of the domestic hot water. In this case the check valve of the Electric-heater-circulator is closed and the check valve to the boiler is open as long as the hot water heater feed pump is running.

As soon as the main switch of the Electric heater-circulator is turned on,

the relay on the additional printed circuit board closes and switches the lead from the hot water heater feed pump to the control inlet of the Electric heater-circulator. At the same time the control lead for the boiler is interrupted, which ensures that the boiler and the Electric heater-circulator cannot be working at the same time. Each time the boiler control switches on the hot water heater feed pump, the Electric heater-circulator is turned on instead.

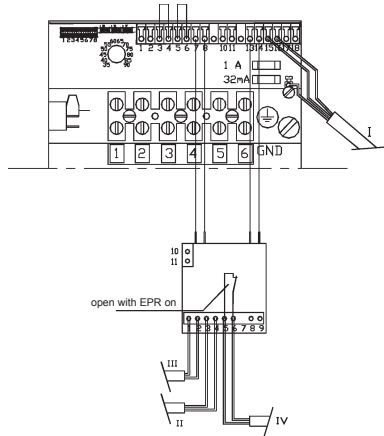

Wiring diagram control method 1

Control method 2

For this control method it is necessary to install an additional thermostat into the hot water heater that closes when heat for the hot water heater is needed. The wiring has to be performed according to the diagram below, whereby the additional heater thermostat has to be connected to the terminal CS4. A control lead IV has to be connected to CS3 which prevents the burner from turning on when the electric heating is active.

As long as the electric heating is switched off via the main switch the relay on the additional printed circuit board is de-energized and the control contact of this relay.

for the burner is closed, so that the boiler now performs the heating of the domestic hot water. In this case the check valve of the Electric heater-circulator is closed and the check valve for the boiler is open as long as the hot water heater feed pump is running. As soon as the main switch of the Electric heater-circulator is closed, the relays on the additional printed circuit board closes and separates the control lead to the burner. Now the Electric heater-circulator will be controlled via the additional thermostat installed within the hot water heater.

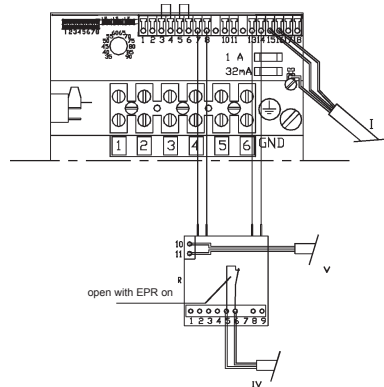

Wiring diagram control method 2

Operation of heating elements with a load shedding device

The control of the electric heater circulator unit is perfectly suited for operation with a load shedding device.

Normally, utility companies will provide a load shedding device with a potential free contact which is closed when electrical heating is permitted and open when electrical heating is not permitted.

- If the load shedding device should not control all heating elements, the switching contact RR of the load shedding device needs to be connected to terminals 1 and 2 of the electric heater circulator unit. In this case, the main power should be connected as described in the chapter "Power Supply".

In this case, the first heating element is always activated when heating is required, and for the second and third heating element jumpers 6 and 7 control whether they are controlled by the load shedding device. If the appropriate jumper is closed, the element heats always when heat is requested. If it is open, the heating element only heats when in addition to the heat request the contact between terminal 1 and 2 is closed. In this way, it is possible to control one third or two thirds of the total heating power by a load shedding device.

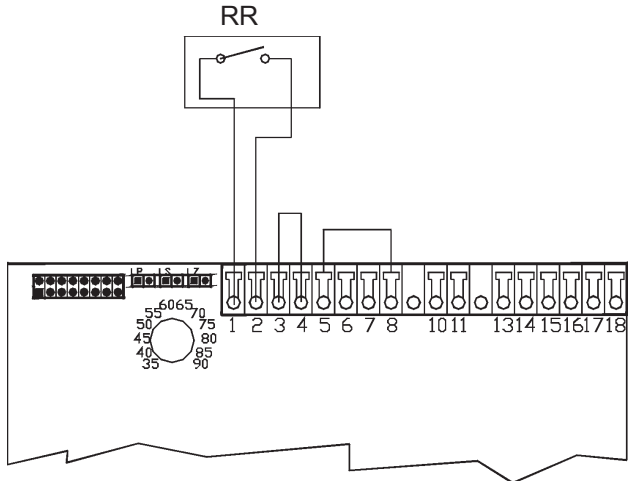

Wiring schematics for load shedding device if only one or two heating elements are to be controlled by the load shedding device.

- If all three heating elements should be controlled by a load shedding device, the unit needs to be connected according to the diagram below. The diagram shows the connection for 3-phase 400 Volt operation. For other supply voltages, the corresponding diagram shown under “main power connection“ should be modified accordingly.

If all three elements are controlled by a load shedding device, a separate power supply is needed for the control and the circulator pump, so that these two can operate independent of the load shedding device. This is necessary since an operation of the unit without deferred pump shutdown can lead to overheating conditions when the elements are deenergized.

Remove the jumper wire between Mains terminal 1 and terminal T on the main switch. Attach the separate power supply to terminal T. A separate switch H1 controls the operation of pump and control as well as the contactor for the main power supply.

If the load shedding device RR is open but the switch H1 and the main switch of the electric heater circulator unit are on, the control and the pump will operate. When the contact RR is closed, the external contactor closes and the heating elements are activated in accordance with heating requirements and selected heating program.

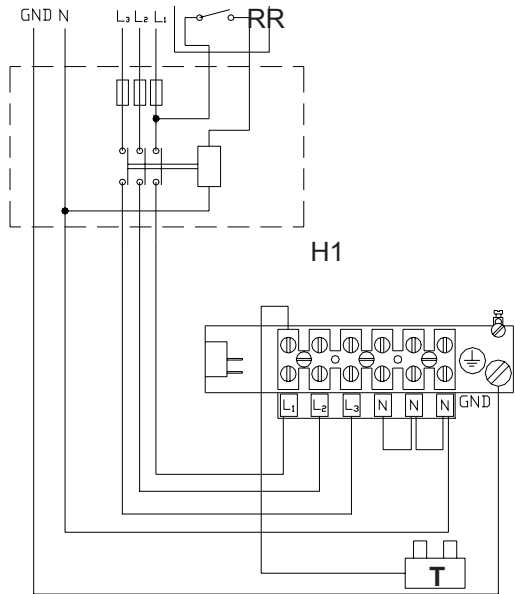

Wiring schematics for control of all heating elements by load shedding device

Filling of the system

One has to take care that the whole system is completely filled.

In filling and bleeding of a floor heating system one has to take into consideration that the gases released from the water have no opportunity to accumulate for instance in radiators as in other heating systems. In a floor heating the gases will always circulate in the heating loops. In cases with high emission of gas the circulator may stop running, whereby the bearing, due to dry running, can be damaged. Therefore one has to take care that after about two weeks the collected gases are completely vented, and that a comparable amount of water is added.

The electric heating should only be started after complete filling and bleeding of the system.

Pressure and leak tests

When pressure-testing the system, the expansion tank, the pressure relief valve, and the manometer should never be exposed to the pressure necessary to perform the pressure test. These parts have to be removed and the holes have to be plugged.

Starting operation

The system can only be started when it is completely filled and when the control system has been tested. When using a remote control one has to make sure that the feed line sensor is attached to the feed line. In addition one has to take care that the jumper of the control are in the right position to guarantee the desired functions.

If these preconditions are fulfilled, the pump can be switched on first by setting the constant temperature at knob K at the lowest value and by activating the main switch. It is possible that there could be some noise in the system due to residual air. If this noise does not stop after a few minutes or if no liquid is circulated by the pump, the pump should be switched on and off several times (about 10 seconds off, 20 seconds on) to enhance the air venting. If this method does not succeed after about 10 minutes, the filling of the system has to be repeated since apparently there is still a large amount of air in the system.

In no case should the pump run longer than a few minutes in a system inadequately vented since the bearing can be damaged.

After a successful start of the pump in a floor heating system the unit should run for about 24 hours without heating to give the water time to get rid of the gases. After this time the heating should start by slowly increasing the feed line temperature via the constant temperature setting. During the whole starting operation the system has to be controlled and the water which is diminished by the release of the gases has to be replaced and the gases have to be vented.

If this advice is not followed, there is the danger that the air accumulates in the pump and interrupts the circulation of the pump. In this case the bearing can also be damaged.

Replacement of the circulation pump

In case it is necessary to open or replace the circulator of the Electric heater-circulator, the Electric heater-circulator has to be separated from the grid and the water has to be drained.

If the LAING Compact station is used, the return line valves of all heating loops have to be closed and a hose has to be attached to the lower KFE tap. After opening the KFE tap about 4 to 8 liters of water will be discharged.

Now the pump has to be taken off by unscrewing the two fastening screws. When the pump is removed it should not be tilted too much since otherwise the rotor might fall out and could be damaged. After the pump has been removed the rotor can be drawn off upwards and can be tested for dirt or scaling.

In replacing the pump the rotor has to be replaced before the seal ring otherwise there could be damage. Before the Electric heater-circulator is started again the air has to be vented in any case.

Replacement of the safety temperature limiter STBR

To replace the switching module of the safety temperature limiter the leads of the safety temperature limiter have to be marked and then disconnected. Thereafter, the switching module has to be removed by unscrewing the nut around the reset knob Z at the outside of the control box. Then the capillary has to be carefully removed from the immersion shell. One has to take into account that the temperature sensors are also contained in the immersion shell.

Afterwards, the temperature sensors have to be removed from the old capillary and be attached to the new capillary in the same position directly above the thick area of the capillary. This point is very important since an improper mounting can lead to a malfunction of the control.

Then the capillary has to be carefully replaced into the immersion shell until it touches the bottom. Thereafter, the safety temperature limiter has to be secured by the nut and the leads have to be connected to the same positions as before.

Replacement of the main circuit board EPRH

To replace the main circuit board the Electric heater-circulator has to be disconnected from the grid and thereafter, the cover from the terminal box has to be removed.

Then two snap connectors M have to be disengaged by pressing with a screw driver from above on the tongue of the connector (see page ...). Thereafter the circuit board can be pulled out. One has to take care that the leads that are pinned to the circuit board will not get stuck. When the circuit board has been moved up high enough, the leads can be removed.

Before the circuit board is reinserted, the plugs have to be fully inserted into the board. One has to make sure that the slots in the circuit board fit into the bars of the plugs.

Thereafter the circuit board is pushed downwards until the snap connectors are in the right position and the board can be snapped in.

Important Notices

Important Notice: How to avoid noise problems

Since the Electric heater-circulator is often used in living quarters, it is especially important to avoid noise. In this respect it is very important that the Electric heater-circulator and the connected pipes are always joined by rubber isolatorsto avoid direct sound transmission. This applies also to pipes installed inside the walls.

Important Notice: How to avoid overheating

To avoid overheating of the Electric heater-circulator it is obligatory that during the heating cycle the Electric heater-circulator is continuously filled with water. If the feed line or the return line will be shut off as for instance in a floor heating system, in which all loops have a zone control, the optionally available Laing Zone module with pump shut off has to be installed. This will shut off the pump until a through flow is possible again. In heating systems with radiators a relief valve has to be installed.

Important Notice: In the event of safety temperature limiter failure

When the safety temperature limiter will become very hot, as can be the case when the Electric heater-circulator is switched on and off several times without being filled with water, the safety temperature limiter will switch off once more to avoid a further overheating. However, it may not be possible to switch it on again since the high temperatures may have destroyed the element. This damage is recognizable when the knob of the switch for the safety temperature limiter cannot be engaged any more. If this is the case, the safety temperature limiter has to be replaced.

Important Notice: For proper connection to a floor heating system

All parts of the Electric heater-circulator and all other components which are part of the Laing compact- or central stations, which come in contact with the liquid conveyed are corrosion resistant. Therefore it is possible to provide a direct floor heating system connection even if the pipes are not diffusion protected.

However, this applies only when the whole floor heating loop consists of corrosion resistant material. In any case installations having corroding materials such as iron expansion tanks, iron pipes or radiators should be avoided. In such installations – even when they are diffusion protected – excessive corrosion will occur in a short time on the iron parts which in turn can lead to other damages and even water leaks in the system. In these systems only a separation between the systems can solve the problem.

Factory settings

Constant temperature control	50°C
Safety temperature cutout	60°C

Jumper 1	closed	Jumper 5	open
Jumper 2	open	Jumper 6	closed
Jumper 3	open	Jumper 7	closed
Jumper 4	open	Jumper 8	closed

Switching sequence	Jumper	1	2	3	4
A Simultaneous switching		closed	open	open	open
B Switching in temperature steps		open	closed	open	open
C Switching staged over time		open	open	closed	open
D Switching depending on a gradient		open	open	open	closed

In connection with an outside temperature guided control only A and C can be used.

Jumper	Function jumper closed	Function jumper open
6	After switching off the heating elements the circulator runs another two minutes	Circulator runs always as long as the main switch is turned on
7	Second heating element activated	Second heating element deactivated
8	Third heating element activated	Third heating element deactivated
8	Overheating safety switch activated	Safety temperature switch not activated

Malfunction reports and LED's

(the green LED is always on when the main switch is turned on and there is a connection to the grid, the yellow LED is on when the control requests heat and when the heating elements are activated.)

Malfunction	Signal	red LED	yellow LED
Circulator malfunction		blinking	on
Excess temperature cutout		on	on
Safety temperature limiter		blinking	off
Dry operation		on	off
Jumper 1 to 4 wrong position		blinking	blinking

The malfunction signal "Jumper 1 to 4 wrong position" means that more than one jumper is closed or all four jumpers are open. From the jumpers 1 to 4 only one jumper must be closed.

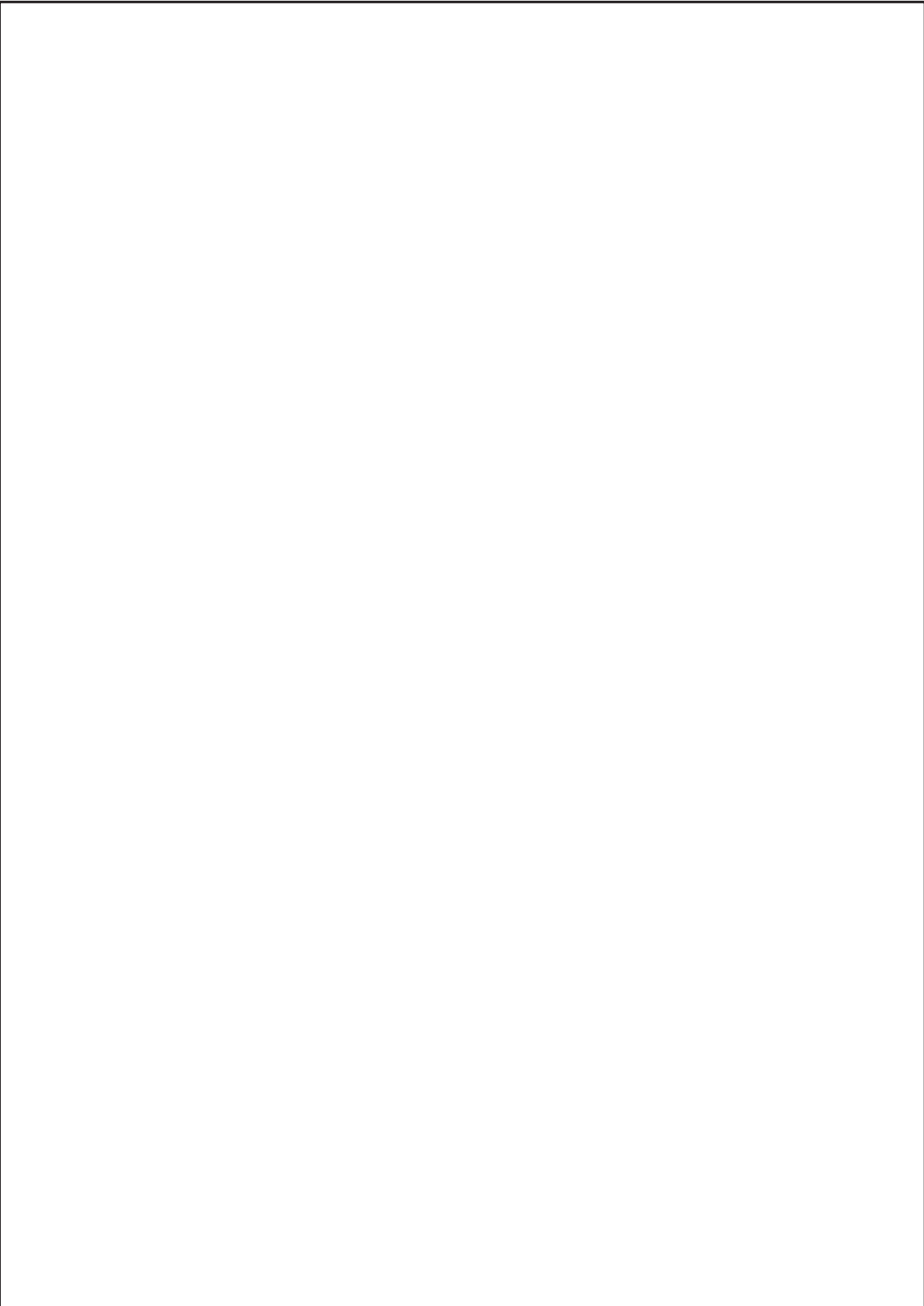

About us

Since the 1950s we at Laing have worked in the areas of research, development and production of pumps and heating products. More than 1000 patents worldwide resulted from this work. The original R&D institute located in Southern Germany has over the years evolved into an international company with additional locations in the US, Japan and Hungary and with more than 400 employees. Today, our program consists of:

- Pumps (Shaftless spherical motor pumps)
- Floor heating system connection
- Special products
- Heating controls
- Electrical heaters

We are a flexible and competent partner in the area of pumping and heating. We invite you to try our high quality, economic products.

19022002 - 2 The company reserves the right to make technical alterations!

LAING

Laing GmbH Systeme für Wärmetechnik
Klingelbrunnenweg 4 · 71686 Remseck · Germany
Phone +49 (0)7146/93-0 · Fax +49 (0)7146/93-33
E-Mail: info@laing.de · Homepage: www.laing.de